

DS2200

Ultra Compact Laser Scanner



Compact Dimensions

500
scans/s

150 g
Lightweight



WINHOST™



Unattended Scanning Systems

General Description

Ultra compact dimensions, high performance, versatile connectivity and programmability make the DS2200 the ideal component for OEM and other applications where integration capability and high reliability are essential and cost effectiveness is a key element.

Datalogic's advanced technology and experience in miniaturized laser components has allowed the development of one of the most compact industrial laser scanners on the market without compromising reading performance and industrial quality standards.

The DS2200's high scanning speed and optical quality, together with the new generation real time decoder and flexible decoding software provide high decoding performance and reliability for the most popular bar code symbologies, as well as on damaged or poorly printed bar codes.

Integration into automated equipment is extremely easy thanks to the DS2200's miniature dimensions and its light weight. The dual serial interface increases the device's versatility and connectivity, allowing multi-point scanning configurations through Master-Slave or Multiplexer connections. User friendly set-up procedures are performed through the easy and intuitive WINHOST™ software. The DS2200-2xxx models also provide excellent performance on very high density codes.

DS2200 represents Datalogic's response to the high technological needs of OEMs requiring extremely compact and cost effective components for integration into their automatic equipment. Thanks to Datalogic's recognized high quality standards, system manufacturers can be confident that the scanners installed in their machines will improve overall system performance and reliability.

Features

- > Ultra compact dimensions
50 x 40 x 28 mm (1.97x1.57x1.10 in)
- > Lightweight: 150 g (5.29 oz)
- > New generation built-in real time RISC decoder
- > Scanning speed of 500 scans/sec
- > Very high density code reading
(up to 0.076 mm / 3 mils)
- > Dual serial interface
- > Easy set up through WINHOST™
- > IP65 rugged industrial housing

Applications

- > Automatic machines
- > Chemical and biomedical analyzers
- > Document handling machines
- > Printing verification
- > Film processing machines
- > Packaging machines

Specifications

ELECTRICAL CHARACTERISTICS

POWER SUPPLY 5 VDC ±5% (4 to 30 VDC with converter)
 POWER CONSUMPTION 2 W

MECHANICAL CHARACTERISTICS

DIMENSIONS 50 x 40 x 28 mm (1.97 x 1.57 x 1.10 in)
 WEIGHT (without cable) 150 g (5.29 oz)
 CASE MATERIAL Die-cast zinc

PERFORMANCE

LIGHT SOURCE Visible laser diode (650 nm)
 MAX. RESOLUTION 0.15 mm (6 mils) for standard resolution models
 0.076 mm (3 mils) for high resolution models
 SCANNING SPEED 500 scans/sec
 MAX. READING DISTANCE 220 mm (on 0.60 mm/24 mils codes) for standard resolution models
 125mm (on 0.20 mm/8 mils codes) for high resolution models
 MAX. DEPTH OF FIELD 170 mm (on 0.60 mm/24 mils codes) for standard resolution models
 85 mm (on 0.20 mm/8 mils codes) for high resolution models
 APERTURE ANGLE 52 degrees for standard resolution models
 62 degrees for high resolution models
 RASTER APERTURE 15 mm (0.6 in) at 220 mm (8.7 in) for raster models
 READABLE CODES Code 2/5, Code 39, Code 93, Code 128, EAN/UPC, EAN128, Codabar, Pharmacode
 MULTILABEL READING Up to 6 different codes in the same presence sensor phase
 COMMUNICATION INTERFACE Dual serial interface (RS232+RS485 half duplex)
 BAUD RATE Up to 115.2 Kbauds
 INPUT SIGNALS One external trigger digital input
 OUTPUT SIGNALS Two programmable digital outputs
 PROGRAMMING METHOD Via serial port (WINHOST™)
 OPERATING MODES 'On line,' 'Serial On-line,' 'Automatic,' 'Test,' 'Verifier'
 LED INDICATORS 'Power On,' 'External Trigger,' 'Good Read,' 'TX Data'
 LASER CLASSIFICATION IEC 825 Class 2
 LASER CONTROL Security system to turn laser off in case of motor slow down or failure

ENVIRONMENT
 OPERATING TEMPERATURE 0 to 40 °C (32 to 104 °F)
 STORAGE TEMPERATURE -20 to 70 °C (-4 to 158 °F)
 HUMIDITY 90% non condensing
 VIBRATION RESISTANCE IEC 68-2-6 test FC 1.5 mm; 10 to 55 Hz; 2 hours on each axis
 SHOCK RESISTANCE IEC 68-2-27 test EA 30 G; 11 ms; 3 shocks on each axis
 PROTECTION CLASS IP65

Dimensions

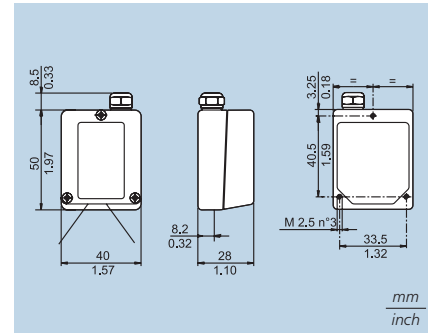

Reading Diagrams

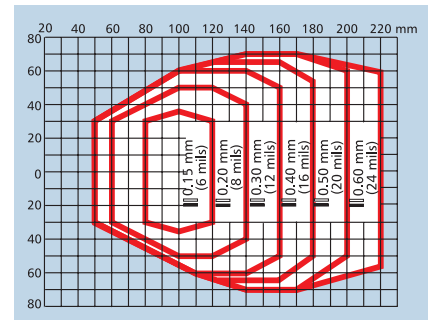

Standard Resolution Models

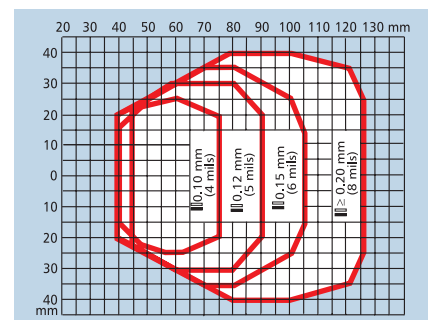

High Resolution Models



KUMAIDENT GmbH, Dieselstraße 18, 70771 Leinfelden-Echterdingen
 Tel.: 0711/16069-60, info@kumaident.com, www.kumaident.com