

# MATRIX-2XX5 MP

1D & 2D, Stacked, Postal Code  
1.3 MP Area Reader

**DATALOGIC**  
Your Life. Our Enthusiasm™

**Wide  
FoV**  
(covers an  
A5 sheet)



**VisiSet™**  
via  
**Ethernet**



Unattended Scanning Systems

## General Description

Matrix-2XX5 MP is an area CMOS reader for industrial applications requiring a wide field of view (FoV) while using 1D, 2D, stacked and postal codes. For example, the wide FoV Matrix models based on a 1.3 Megapixel sensor are suitable for CD/DVD identification using a single reader. Multicode simultaneous reading is also possible, such as in biomedical applications (96 vial rack reading in a single image acquisition). The fully integrated reader combines a LED lighting system, image capturing, decoding and communication interfaces in a single compact product. Matrix-2XX5 MP offers full programmability via Ethernet, an Autolearning function for quick installation and set-up without a PC, and DPM (Direct Part Marking) decoding capabilities.

In addition to the VisiSet™ software configuration, Matrix-2XX5 MP Ethernet connectivity offers several communication channels, such as TCP/IP socket for data and image transfer, HTTP server, FTP and mail client.

Matrix-2XX5 MP AIM standards diagnostic software tools enable real time monitoring of code printing quality, position and orientation, exposure quality and decoding time on all decoded symbologies.

Matrix-2XX5 MP state-of-the-art decoding libraries are extremely effective on damaged and low quality bar code applications. The reader flexibility allows a smooth transition from standard bar code reading to 2D code symbologies.

Matrix-2XX5 MP is ready for use in various applications, offering many optical solutions to guarantee high accuracy in identifying codes with different resolutions at various distances with the best reading performance in its class. Customized solutions for specific applications are also available upon request.

## Features

- > Up to 100 codes in a single frame
- > Up to 16 full frames/s (960 frames/min)
- > 1D & 2D, stacked, postal code reading
- > Autolearning function
- > Code quality control (AIM)
- > Ethernet configuration/data collection
- > Image transfer capability via Ethernet
- > Integrated LED lighting system

## Applications

- > 96 vial rack reading
- > CD/DVD identification
- > WIP control / product traceability
- > Document and mail processing
- > PCB production line tracking
- > Direct Part Marking (DPM) applications
- > Semiconductor production line tracking
- > Chemical and biomedical analysis machines
- > Small objects/pharmaceutical packaging

# MATRIX-2XX5 MP

1D & 2D, Stacked,  
Postal Code  
1.3 MP Area Reader

## Specifications

### ELECTRICAL CHARACTERISTICS

POWER SUPPLY 10 to 30 Vdc  
POWER CONSUMPTION 8 W max.; 5 W typ.

### MECHANICAL CHARACTERISTICS

DIMENSIONS 121 x 73 x 57 mm (4.76 x 2.87 x 2.24 in)  
WEIGHT 380 g (13.40 oz)  
CASE MATERIAL Magnesium alloy

### PERFORMANCE

OPTICAL FEATURES SXGA format CMOS sensor / LED array lighting systems  
FRAME RATE Up to 16 frames/s (SXGA); up to 64 frames/sec (VGA)  
READING ANGLES Max. Pitch:  $\pm 35^\circ$ ; Tilt:  $360^\circ$   
READABLE SYMBOLOGIES DataMatrix, QR Code, PDF417, I 2/5, Code 128, Code 39, EAN/UPC, postal codes and many more  
COMMUNICATION INTERFACE RS232 + optocoupled RS232/RS422/RS485 up to 115.2 Kbit/s  
Ethernet IEEE 802.3 10 Base T and IEEE 802.3U 100 BaseTx compliant  
CONNECTIVITY modes Pass Through, Master/Slave, Multiplexer, ETH point to point and network  
DIGITAL INPUTS Two SW programmable, optocoupled and polarity insensitive  
DIGITAL OUTPUTS Three SW programmable optocoupled  
PROGRAMMING METHOD Windows™ based configuration software (VisiSet™) via serial or Ethernet link  
DIAGNOSTIC SW TOOLS AIM standards diagnostic tools on all symbologies decoded  
USER INTERFACE Beeper, Keypad Button, LEDs (PWR, TRIG, READ, COM, POS, CAL)

### ENVIRONMENT

OPERATING TEMPERATURE 0 to 40 °C (32 to 104 °F)  
STORAGE TEMPERATURE -20 to 70 °C (-4 to 158 °F)  
HUMIDITY 90% non condensing  
VIBRATION RESISTANCE IEC 68-2-6 test FC 1.5 mm; 10 to 55 Hz; 2 hours on each axis  
SHOCK RESISTANCE IEC 68-2-27 test EA 30 G; 11ms; 3 shocks on each axis  
PROTECTION CLASS IP64 (20X5 models)

## Dimensions

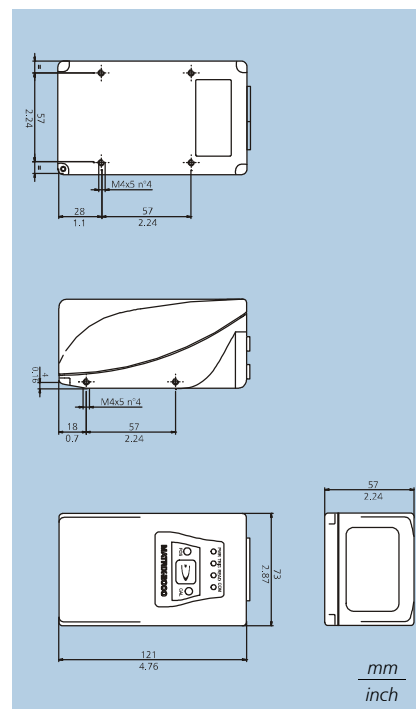

## Reading Characteristics

MODEL / DESCRIPTION <sup>1</sup>	FOCUS DISTANCE mm (in)	FIELD OF VIEW @ focus distance mm x mm (in x in)	PPI @ focus distance	TYP. LINEAR & STACKED CODE RESOLUTION mm (mils)	TYP. 2D CODE RESOLUTION mm (mils)	READING DISTANCE	
						MIN. mm (in)	MAX. mm (in)
MATRIX-2X25 HD MP	135 (5.31)	65 x 52 (2.56 x 2.05)	500	0.10 (4)	0.19 (7.5)	120(4.72)	150(5.90)
MATRIX-2X45 LD MP	100 (3.94)	120 x 96 (4.72 x 3.78)	270	0.20 (8)	0.38 (15)	80(3.15)	120(4.72)
MATRIX-2X55 MR MP	180 (7.09)	215 x 172 (8.46 x 6.77)	150	0.30 (12)	0.60 (24)	140(5.51)	240(9.44)

<sup>1</sup> = 20X5 serial models; 21X5 Ethernet models.

## Applications

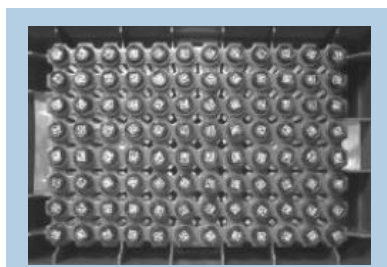

96 vial rack reading



CD/DVD identification



Multicode A5 sheet reading

**DATALOGIC**  
Your Life. Our Enthusiasm™

www.datalogic.com | info@datalogic.com

Product and Company names and logos referenced may be either trademarks or registered trademarks of their respective companies. We reserve the right to make modifications and improvements.



Datalogic Communication Division  
Printed in Italy in October 2005



KUMIdent GmbH  
Dieselstraße 18  
70771 Leinfelden-Echterdingen  
Telefon 0711/160 69 60  
Telefax 0711/160 69 66  
info@kumident.com