

DS2100A

General View:

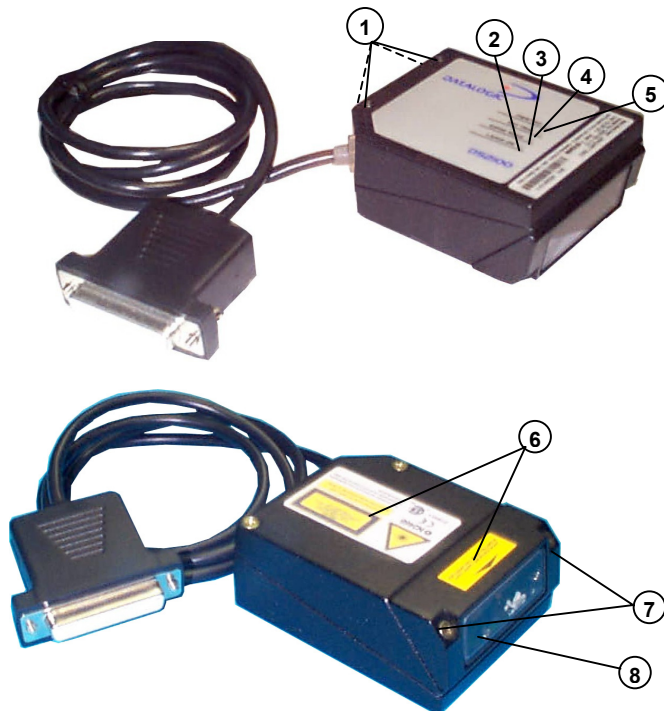

Figure A

- | | |
|------------------------|-----------------------------------|
| ① Mounting Holes | ⑤ Power On / Data TX LED |
| ② Laser On LED | ⑥ Warning and Device Class Labels |
| ③ Good Read LED | ⑦ Accessory Mounting Holes |
| ④ External Trigger LED | ⑧ Laser Beam Output Window |

For further details on product installation, see the complete Reference Manual on the installation CD-ROM.

DS2100A can be configured through the WinHost Windows-based software program available on the installation CD-ROM.

For configuration it is necessary to create a cable connecting the scanner to the PC as indicated in the "How To Build A Simple Interface Test Cable" section of this guide, otherwise you can use the C-Box 100.

Power Supply:

- This product is intended to be installed by Qualified Personnel only.
- All Models:
This accessory device is intended to be supplied by a UL Listed or CSA Certified Power Unit with «Class 2» or LPS power source which supplies power directly to the scanner via the 25-pin connector.

WEEE Compliance:



Laser Safety:

The scanner is classified as a Class 2 laser product according to EN 60825-1 regulations and as a Class II laser product according to CDRH regulations.

Disconnect the power supply when opening the device during maintenance or installation to avoid exposure to hazardous laser light.

There is a safety device which allows the laser to be switched on only if the motor is rotating above the threshold for its correct scanning speed.

The laser beam can be switched off through a software command (see also the WinHost Help On Line).

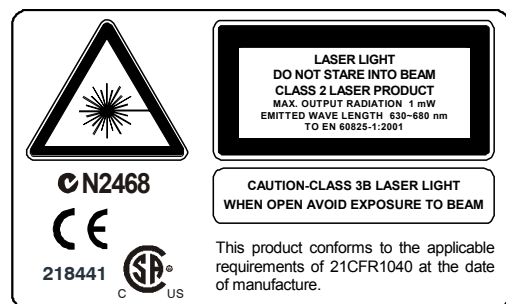

Warning and Device Class Labels

The laser diode used in this device is classified as a class 3B laser product according to EN 60825-1 regulations and as a Class IIIb laser product according to CDRH regulations. As it is not possible to apply a classification label on the laser diode used in this device, the following label is reproduced below.

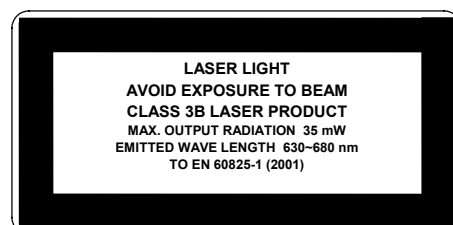

Laser Diode Class Label

Any violation of the optic parts in particular can cause radiation up to the maximum level of the laser diode (35 mW at 630 to 680 nm).

Model Description:

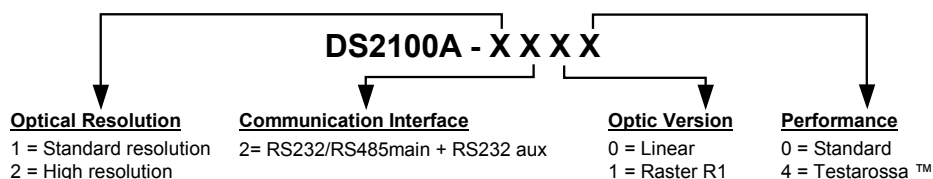

Reading Performance:

| Version | Reading Distance | Max Code Resolution mm (mils) | Speed scans/s |
|---------|--|-------------------------------|---------------|
| 1XX0 | 40 mm (1.6 in) - 300 mm (11.8 in) on 0.50 mm (20 mils) codes | 0.20 (8) | 500 to 800 |
| 1XX4 | 50 mm (1.8 in) - 310 mm (11.8 in) on 0.50 mm (20 mils) codes | 0.20 (8) | 800 to 1000 |
| 2XX0 | 30 mm (1.2 in) - 90 mm (3.5 in) on 0.30 mm (12 mils) codes | 0.15 (6) | 500 to 800 |
| 2XX4 | 45 mm (1.8 in) - 100 mm (3.9 in) on 0.20 mm (8 mils) codes | 0.12 (5) | 800 to 1000 |

Technical Features:

| ELECTRICAL FEATURES | | SOFTWARE FEATURES | |
|----------------------------------|---|---|---|
| Power Supply | 10 -30 Vdc | Readable Codes * EAN/UPC (including Add-on 2 and Add-on 5) * Code 39 * 2/5 Interleaved * Code 128 * EAN 128 * Codabar * Code 93 * ISBT 128 * Pharmacoce * = ACB readable | Up to four header and four terminator characters On-Line, Automatic, Serial-On-Line, Test Through menus using: WinHost utility Host Mode (commands from one of the serial ports) |
| Power Consumption | Model XXX0: 3W Model XXX4: 5W | | |
| Main Serial Interface | Programmable: RS232; RS485 Full-Duplex/Half-Duplex; | | |
| Auxiliary Interface | RS232 | | |
| Baudrates | 150 to 115200 | | |
| Inputs | | | |
| External Trigger | (optocoupled NPN or PNP) | | |
| Voltage max. | 30 Vdc | | |
| Current Consumption max. | 25 mA | | |
| Outputs) OUT1, OUT2 | (optocoupled) | | |
| V_{CE} max. | 40 Vdc | Configuration Modes | Up to six different codes during one reading phase Can enable multiple good reads of the same code ACB (Advanced Code Builder) Motor Off Non-volatile internal EEPROM |
| Collector Current max. | 40 mA continuous; 130 mA pulsed | Code Selection | |
| V_{CE} Saturation | 1V at 10 mA max. | Decoding Safety | |
| Power Dissipation max. | 90 mW at 40 °C (Ambient temp.) | Special Functions | |
| OPTICAL FEATURES | | Parameter Storage | ENVIRONMENTAL FEATURES Operating Temperature: 0° to +40 °C (+32° to +104 °F) Storage Temperature: -20° to +70 °C (-4° to +158 °F) Humidity max: 90% non condensing Vibration Resistance IEC 68-2-6 test FC: 14 mm @ 2 to 10 Hz; 1.5 mm @ 13 to 55 Hz; 2 G @ 70 to 200 Hz; 2 hours on each axis |
| Light Source | semiconductor laser diode | Operating Temperature | |
| Wavelength | In the range 630 to 680 nm | Storage Temperature | |
| Safety Class | Class 2 - EN 60825-1; CDRH | Humidity max | Shock Resistance IEC 68-2-27 test EA: 30 G; 11 ms; 3 shocks on each axis Protection Class: IP65 |
| USER INTERFACE | | Vibration Resistance IEC 68-2-6 test FC | |
| LED Indicators | Laser ON, Good Read, External Trigger, Data TX / Power ON | Shock Resistance IEC 68-2-27 test EA | |
| PHYSICAL FEATURES | | Protection Class | |
| Dimensions | 68x83.6x34 mm (2.7x3.29x1.3 in) | | |
| Weight | 330 g. (11.64 oz) | | |

Accessories:

| Name | Description | Part Number |
|------------------------|------------------------------------|----------------------|
| GFC-2100 | 90° Reading Device | 93A201000 |
| GFC-2000 | 75° Reading Device | 93A201080 |
| OM2000 | Oscillating Mirror | 93A251031 |
| INT-30 (for C-Box 100) | 20 mA Current Loop Interface Board | 93A151022 |
| C-BOX 100/200 | Connection Box | 93ACC1510,93ACC1520 |
| C-BOX 300/310 | Connection Box Profibus | 93A301000, 93A301030 |
| C-BOX 400/410 | Connection Box DeviceNet | 93A301010, 93A301040 |
| MEP-542/543 | Photocell Kit NPN/PNP | 93ACC1727, 93ACC1728 |

Electrical Connections:

DS2100A is equipped with a cable terminated by a 25-pin female D-sub connector for connection to the power supply and input/output signals. You can bring system cables directly to the 25-pin connector or you can connect the scanner directly to one of the various C-Box models and bring system wiring to it (see the relative C-Box Installation Manual).



CAUTION Do not connect GND and SGND to different (external) ground references. GND and SGND are internally connected through filtering circuitry which can be permanently damaged if subjected to voltage drops over 0.8 Vdc.

The details of the connector pins are indicated in the following table:

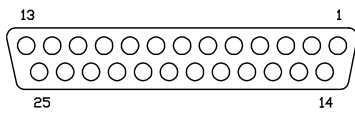
| 25-pin D-sub female connector pinout | | | |
|--------------------------------------|-----------|-----------------------------------|--|
| Pin | Name | Function | |
| 13 | VS | Power supply input voltage + |  <p style="text-align: center;">25-pin female connector</p> |
| 25 | GND | Power supply input voltage - | |
| 1 | CHASSIS | Chassis Ground | |
| 9 | VS | External Trigger supply voltage + | |
| 18 | EXT TRIG+ | External Trigger + | |
| 19 | EXT TRIG- | External Trigger - | |
| 8 | OUT1 + | Output 1 + | |
| 11 | OUT2 + | Output 2 + | |
| 12, 22 | OUT REF | Output reference | |
| 20 | RXAUX | Auxiliary RS232 | |
| 21 | TXAUX | Auxiliary RS232 | |
| 23 | CTSAUX | Auxiliary handshake RS232 | |
| 24 | RTSAUX | Auxiliary handshake RS232 | |
| 6, 10, 14, 15, 16, 17 | NC | Not Connected | |
| Pin | RS232 | RS485 Full-Duplex | RS485 Half-Duplex |
| 2 | TX232 | TX485+ | RTX485+ |
| 3 | RX232 | RX485+ | |
| 4 | RTS232 | TX485- | RTX485- |
| 5 | CTS232 | RX485- | |
| 7 | SGND | SGND | SGND |

Mechanical Installation:

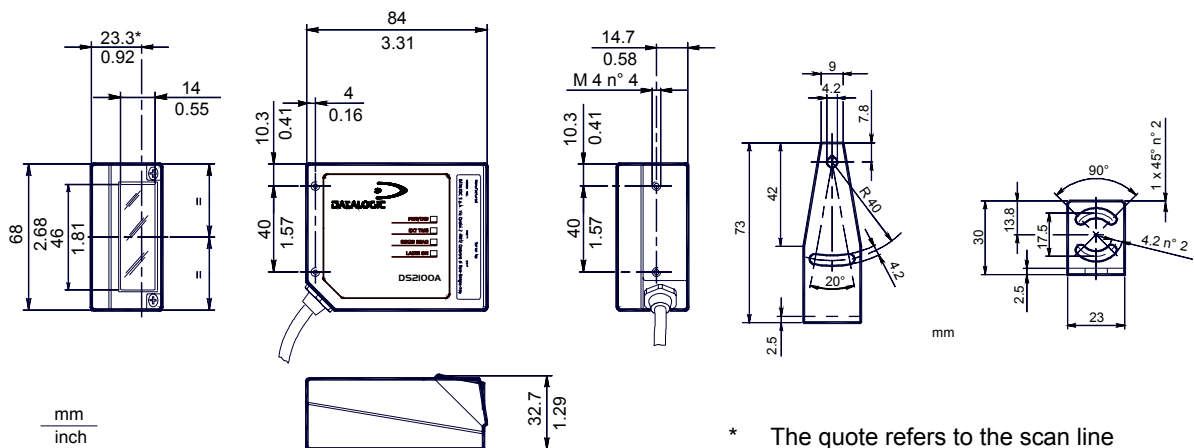

* The quote refers to the scan line

Input/Output Connections:

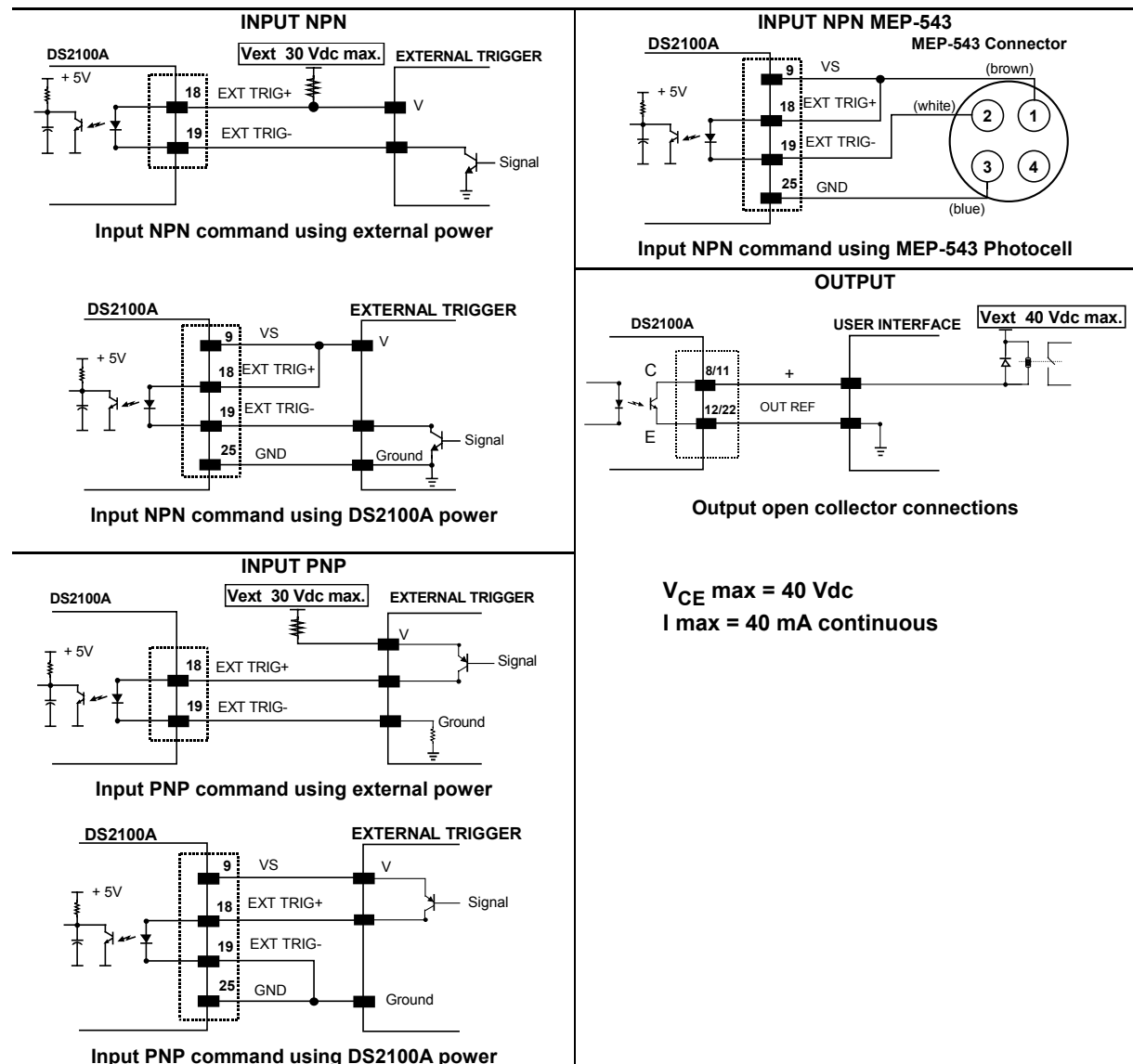

Connectivity:

RS232 Main Interface Connections

RS232 Point-to-point layout

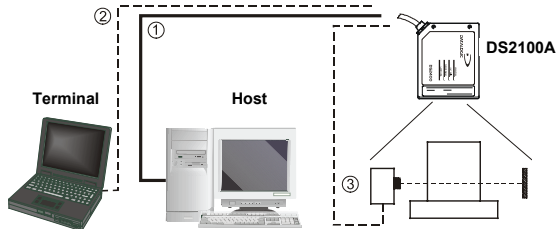

- ① Main Serial Interface (RS232)
- ② Auxiliary Serial Interface (Local Echo) (RS232)
- ③ External Trigger (for On-Line Mode)

Pass-through layout

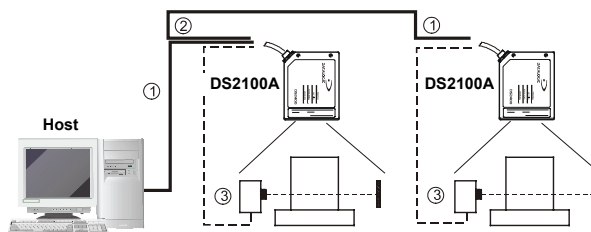

- ① Main Serial Interface (RS232)
- ② Auxiliary Serial Interface (RS232)
- ③ External Trigger (for On-Line Mode)

RS232 Master/slave layout

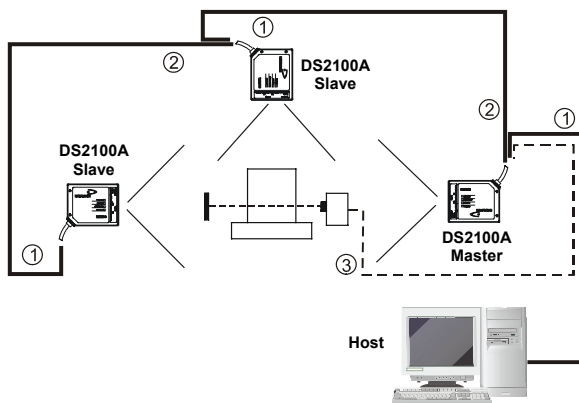

- ① Main Serial Interface (Slaves RS232 only)
- ② Auxiliary Serial Interface (RS232)
- ③ External Trigger (for On-Line Mode)

RS485 Main Interface Connections

RS485 Point-to-point layout

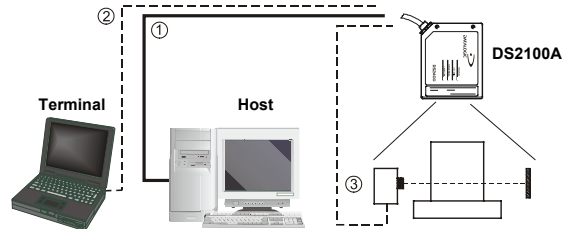

- ① Main Serial Interface (RS485 Full Duplex)
- ② Auxiliary Serial Interface (Local Echo) (RS232)
- ③ External Trigger (for On-Line Mode)

Multiplexer layout

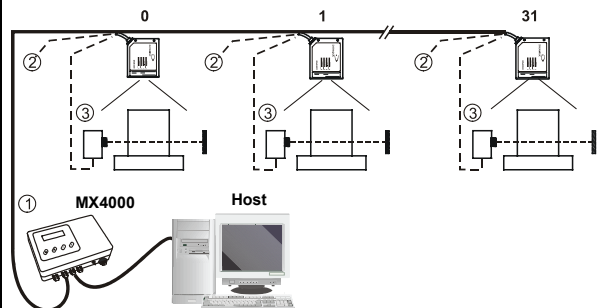

- ① Main Serial Interface (RS485 Half-Duplex)
- ② Auxiliary Serial Interface (Local Echo) (RS232)
- ③ External Trigger (for On-Line Mode)

RS485 Master/slave layout

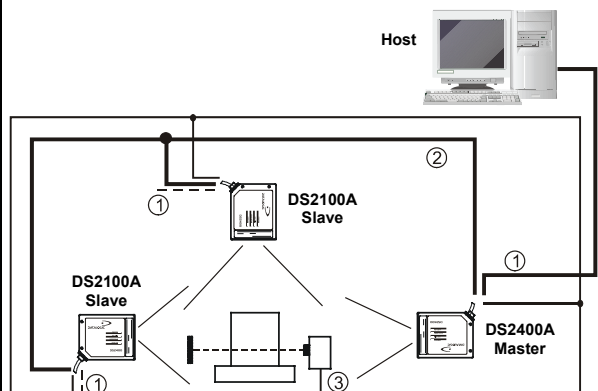

- ① Auxiliary Serial Interface (RS232)
- ② Main Serial Interface (RS485 Half-Duplex)
- ③ External Trigger

Reading Diagrams:

DS2100A-1200 (Standard Resolution, 500 scans/s)

CONDITIONS

Optic Version = Linear
 Code = Interleaved 2/5 or Code 39
 PCS = 0.90
 Pitch angle = 0°
 Skew angle = 15°
 Tilt angle = 0°
 *Code Reading Condition = Standard

* Parameter selectable in Winhost

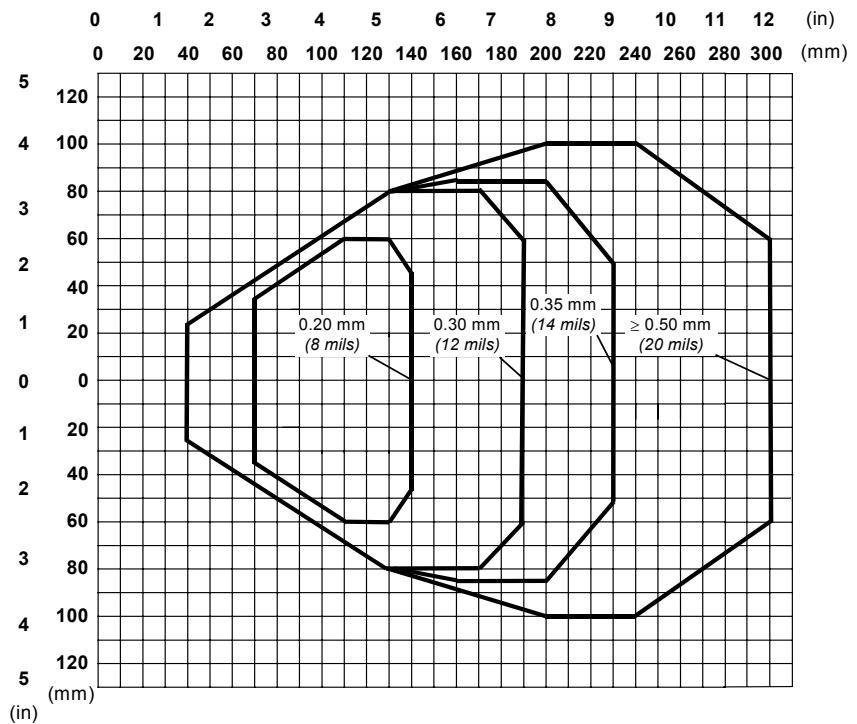

DS2100A-1200 Reading Distance vs Scanning Speed

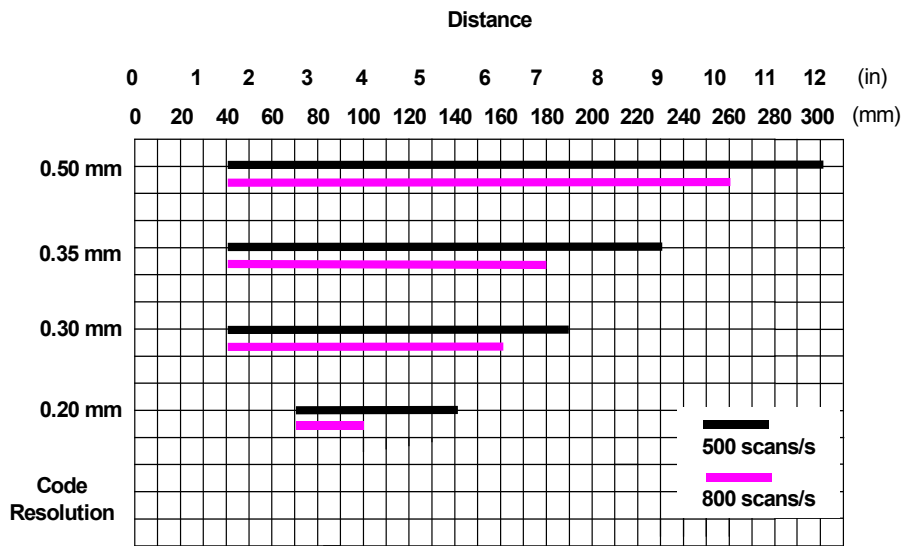

DS2100A-2200 (High resolution, 500 scans/s)

CONDITIONS

Optic Version = Linear
 Code = Interleaved 2/5 or Code 39
 PCS = 0.90
 Pitch angle = 0°
 Skew angle = 15°
 Tilt angle = 0°
 *Code Reading Condition = Standard

* Parameter selectable in Winhost

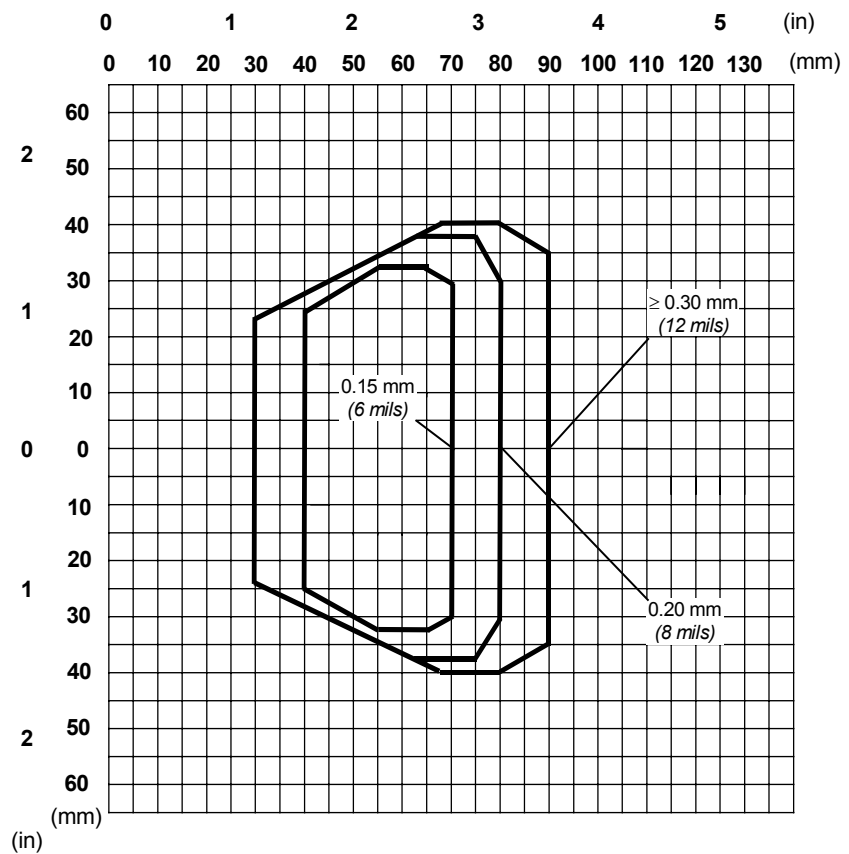

DS2100A-2200 Reading Distance vs Scanning Speed

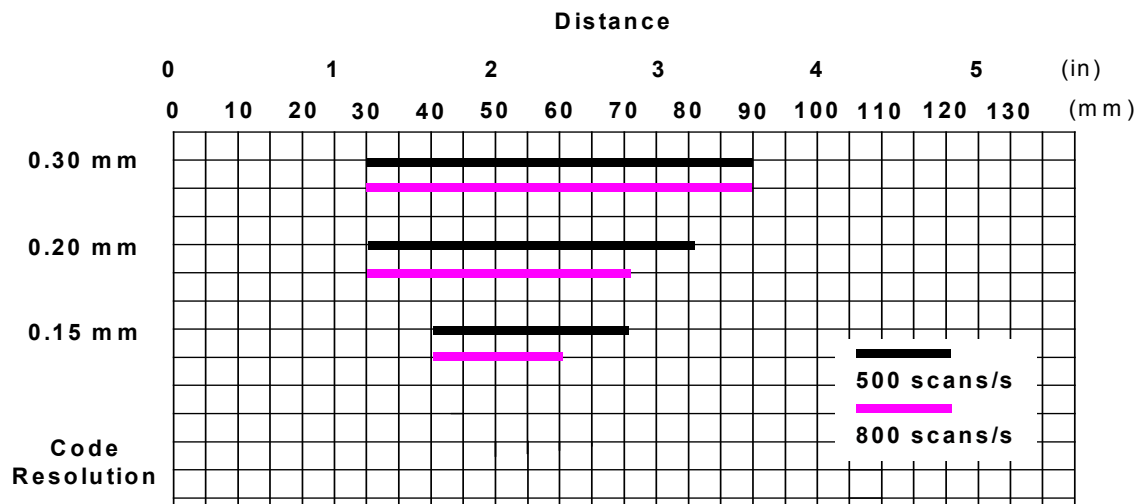

DS2100A-1204 Testarossa™ (Standard resolution, 1000 scan/s)

CONDITIONS

Optic Version = Linear
 Code = Interleaved 2/5 or Code 39
 PCS = 0.90
 Pitch angle = 0°
 Skew angle = 15°
 Tilt angle = 0°
 *Code Resolution:
 High - for 0.30 mm (12 mils)
 codes and smaller
 Standard - for 0.50 mm (20 mils)
 codes and greater
 *Code Reading Condition = Standard

* Parameter selectable in Winhost

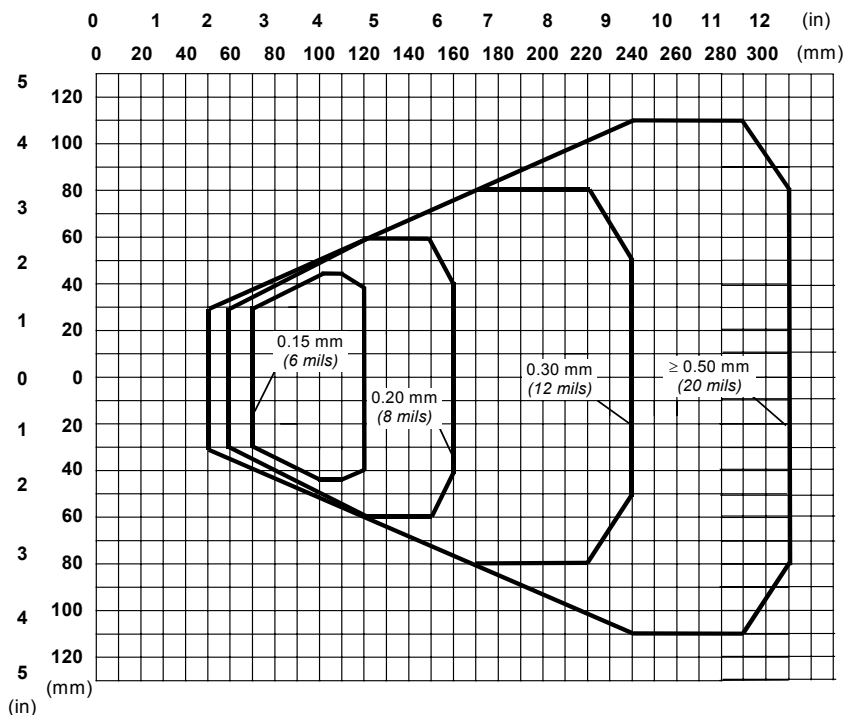

DS2100A-2204 Testarossa™ - (High Resolution, 1000 scans/s)

CONDITIONS

Optic Version = Linear
 Code = Interleaved 2/5 or Code 39
 PCS = 0.90
 Pitch angle = 0°
 Skew angle = 15°
 Tilt angle = 0°
 *Code Resolution:
 High - for 0.15 mm (6 mils) codes
 and smaller
 Standard - for 0.20 mm (8 mils)
 codes
 *Code Reading Condition = Standard

* Parameter selectable in Winhost

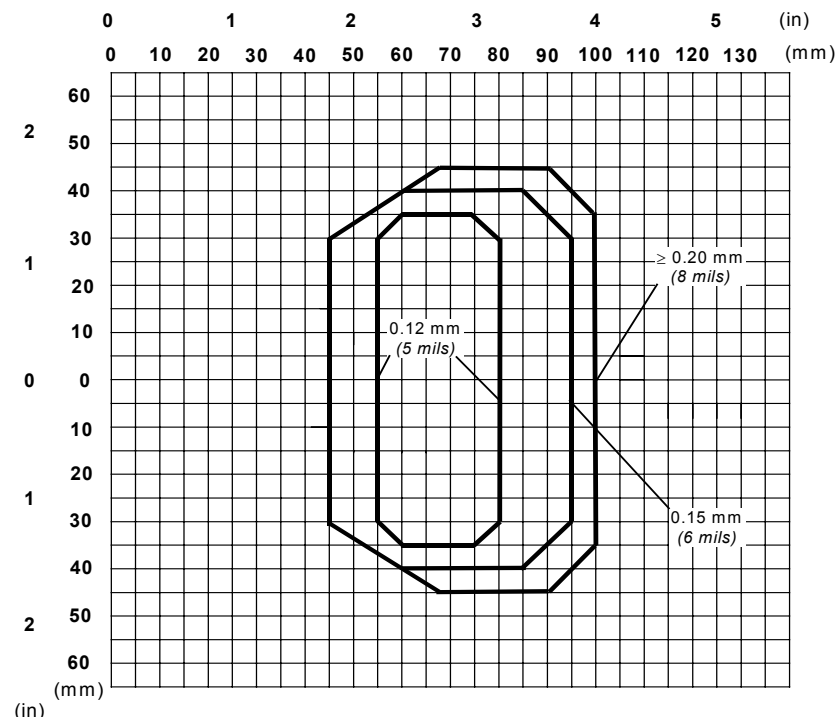

User Interface:

The following table contains the pinout for standard RS232 PC Host interface. For other user interface types please refer to their own manual.

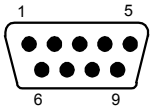
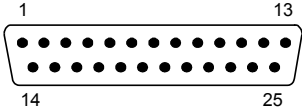
| RS232 PC-side connections | | | |
|---|------|---|------|
|  <p>9-pin male connector</p> | |  <p>25-pin male connector</p> | |
| Pin | Name | Pin | Name |
| 2 | RX | 3 | RX |
| 3 | TX | 2 | TX |
| 5 | GND | 7 | GND |
| 7 | RTS | 4 | RTS |
| 8 | CTS | 5 | CTS |

How To Build A Simple Interface Test Cable:

The following wiring diagrams show a simple test cable including power, external (push-button) trigger and PC RS232 COM port connections.

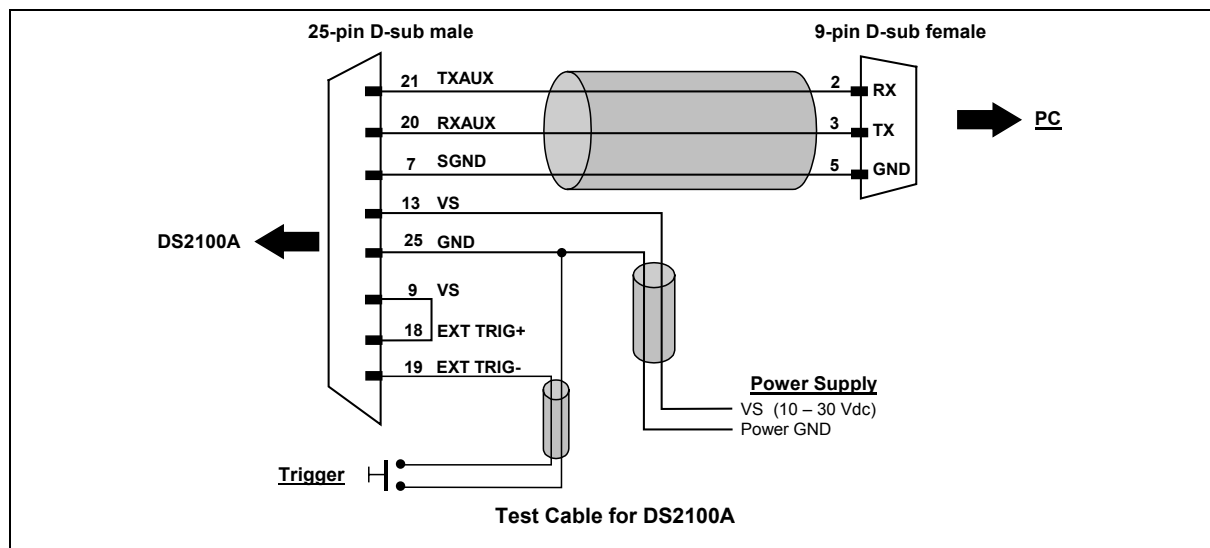

dichiara che
declares that the
déclare que le
bescheinigt, daß das Gerät
declare que el

DS2100A-XXXX Laser Scanner e tutti i suoi modelli
and all its models
et tous ses modèles
und seine modelle
y todos sus modelos

sono conformi alle Direttive del Consiglio Europeo sottoelencate:
are in conformity with the requirements of the European Council Directives listed below:
sont conformes aux spécifications des Directives de l'Union Européenne ci-dessous:
der nachstehend angeführten Direktiven des Europäischen Rats:
cumple con los requisitos de las Directivas del Consejo Europeo, según la lista siguiente:

| | | | |
|---------------------------------|-----|-----------------------------|----------------------------|
| 89/336/EEC EMC Directive | e | 92/31/EEC, 93/68/EEC | emendamenti successivi |
| | and | | further amendments |
| | et | | ses successifs amendements |
| | und | | späteren Abänderungen |
| | y | | sucesivas enmiendas |

Basate sulle legislazioni degli Stati membri in relazione alla compatibilità elettromagnetica ed alla sicurezza dei prodotti.
On the approximation of the laws of Member States relating to electromagnetic compatibility and product safety.
Basée sur la législation des Etats membres relative à la compatibilité électromagnétique et à la sécurité des produits.
Über die Annäherung der Gesetze der Mitgliedsstaaten in bezug auf elektromagnetische Verträglichkeit und Produktsicherheit entsprechen.
Basado en la aproximación de las leyes de los Países Miembros respecto a la compatibilidad electromagnética y las Medidas de seguridad relativas al producto.

Questa dichiarazione è basata sulla conformità dei prodotti alle norme seguenti:
This declaration is based upon compliance of the products to the following standards:
Cette déclaration repose sur la conformité des produits aux normes suivantes:
Diese Erklärung basiert darauf, daß das Produkt den folgenden Normen entspricht:
Esta declaración se basa en el cumplimiento de los productos con las siguientes normas:

EN 55022 (Class A ITE), August 1994:
Amendment A1 (Class A ITE), October 2000:

LIMITS AND METHODS OF MEASUREMENTS OF RADIO DISTURBANCE
CHARACTERISTICS OF INFORMATION TECHNOLOGY EQUIPMENT

EN 61000-6-2, October 2001:

ELECTROMAGNETIC COMPATIBILITY (EMC)
PART 6-2: GENERIC STANDARDS - IMMUNITY FOR INDUSTRIAL
ENVIRONMENTS

Lippo di Calderara, 08/09/2005

Ruggero Cacioppo
Ruggero Cacioppo
Quality Assurance Supervisor